



Sterilized Hands



Super Large Capacity



Contactless

### Liquid Filling Method



1. Easy to use and hygienic: the machine is equipped with automatic infrared sensor, which is very convenient to use, effectively reduces waste, achieves real touch free hand disinfection, and effectively prevents cross sensitivity and re pollution of bacteria.
2. Intelligent control. More energy efficient. This machine uses the most advanced infrared receiving technology, with chip control technology, more stable performance, more accurate control.
3. Wide angle spray, good effect. The nozzle of the sterilizer has a wide angle of liquid shouting, more uniform liquid spraying, and more ideal effect.
4. The design is novel and firm. This series of products are designed by professional industrial design companies, with novel appearance, smooth lines, beautiful and generous, strong and durable.
5. Safe to use. This series of products all have over-current protection. Effectively prevent accidents and ensure safety.
6. Easy to install and maintain. During installation, only the expansion pipe and screw are needed to fix the hook, and then the machine can be hung. Cut off the power supply in case of poor maintenance. This product is suitable for all departments and schools of the hospital. Food factories and pharmaceutical manufacturers, airports, office buildings, restaurants, government agencies and scientific research institutions.

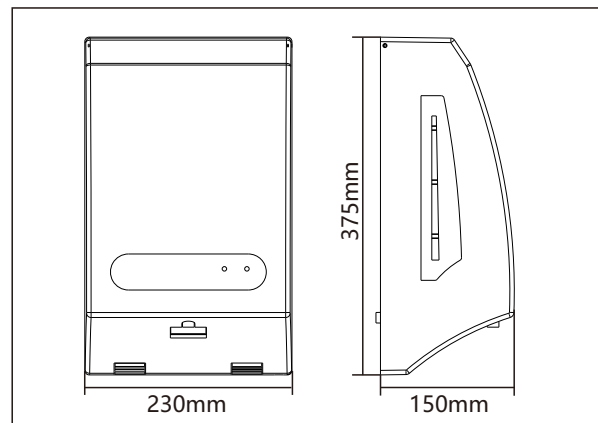

Power Supply:	110V / 220V -- 240V -- 50 / 60Hz
Power:	25W
Environmental Humidity:	≤80%
Ambient Temperature:	5-40 °C
Storage Conditions:	Room Temperature, Clean Room
Spray Volume:	0.6-10ml/s
Tank Capacity:	1800ml
Sensing Distance:	10 ± 3cm
Single Working Time limit:	≤5seconds
Installation Mode:	Wall Mounted
Boundary Dimension:	230*150*375 (mm)
Outer Package Size:	545*415*455 (mm) (QTY: 4, GW: 12kg)

